



JACOBS
ESSSA Group

Cleaning and Cleanliness Measurement of Additive Manufactured Parts

July 18th, 2017

*EM22 – Material Test, Chemistry &
Contamination Control Branch*

Kevin Edwards / MSFC Jacobs ESSSA Group

Eric Fox / MSFC Jacobs ESSSA Group

Mark Mitchell / MSFC NASA

Richard Boothe / MSFC NASA

MARSHALL
SPACE FLIGHT CENTER

Additive Manufacturing

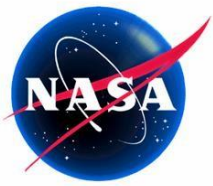

In Additive Manufacturing (AM), layers of material are deposited and selectively fused or melted to form a three dimensional part. Once completed, remnant material must be removed prior to post production processes. However, this can be difficult if the manufactured component has intricate cavities that can trap remnant bulk powder.

NASA MSFC has already encountered problems related to inadequate remnant powder removal. Case in point, blocked channels within AM components.



Selective Laser Sintering



Post Sintering AM Remnant Powder Removal



Remnant Powder Permanently Trapped in Interior Cavities following Inadequate Cleaning & Post Thermal Processing

Standard Gross Remnant Powder Cleaning Methods

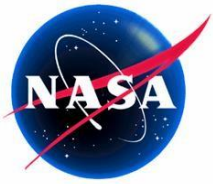

A) Vacuum VS. Compressed Air VS. CO₂ Snow

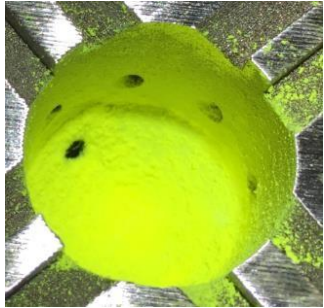

Doped

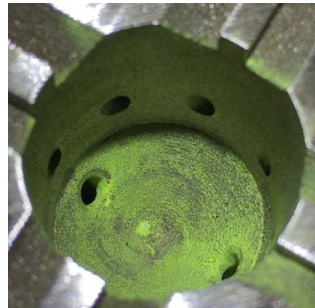

Vacuum



Compressed Air



CO₂ Snow

Pictures of various cleaning methods following fluorescent powder doping

Progression of cleanliness efficiency. (CO₂ Snow yielded the best results.)

B) Wire Probe / Endoscope

Utilized to remove large machined burrs that may be wedged within internal cavities. Hard to remove from blind holes / deep recesses where wire may not be able to reach. Compressed Air, CO₂ Snow, and even Ultrasonic Cleaning are ineffective.



Burrs Trapped in Machined Hole



Gradual Removal of Burr



Burrs Removed (Wire in View)



Relative Size of Burr

Computed Tomography Scan



Method Description:

- X-ray inspection technique that produces 70 cross-sectional slices (1 mm) of the test object, providing accurate geometric / dimensional characterization of internal structure & defects.
- Inspection is performed by rotating the test object between an x-ray source and detector array. Individual x-ray slices are taken while the object rotates. These slices can then be reconstructed into 3D volumes to show internal defects and structures.

Equipment:

- 2 MeV linear accelerator and 450 KeV x-ray tube
- Linear x-ray detector array and amorphous silicon digital x-ray area detector
- Can accommodate objects up to 72" diameter/4000 lbs. on large system (spatial resolution of 0.010-0.030") and up to 10" diameter/50 lbs. on small system (spatial resolution 0.005")

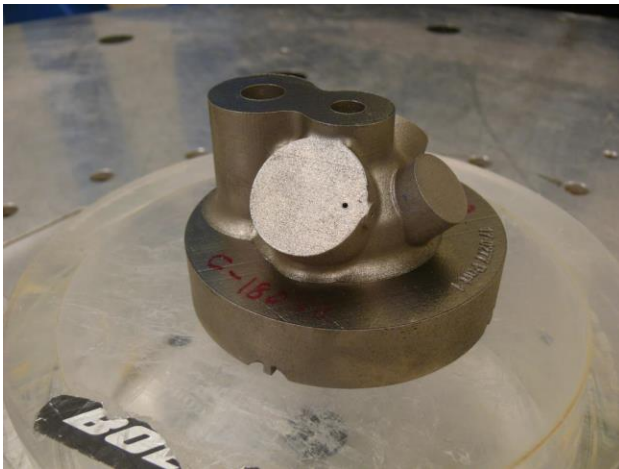

Component Loaded for CT Scanning



Component X-ray image

Component Analysis – Remnant Powder Locations

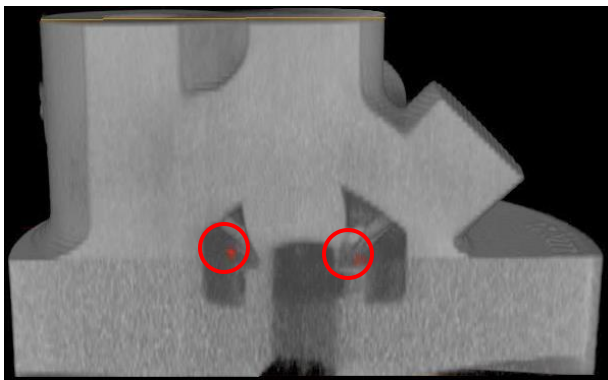

Front

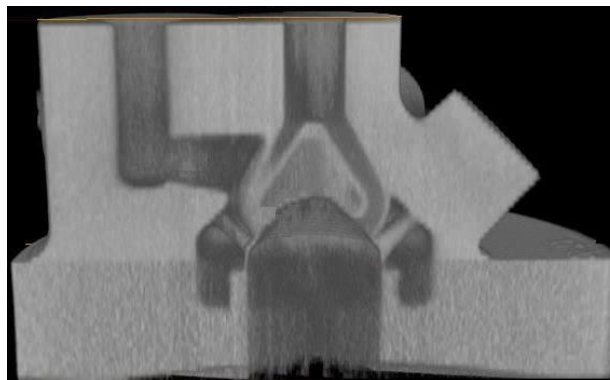

Center

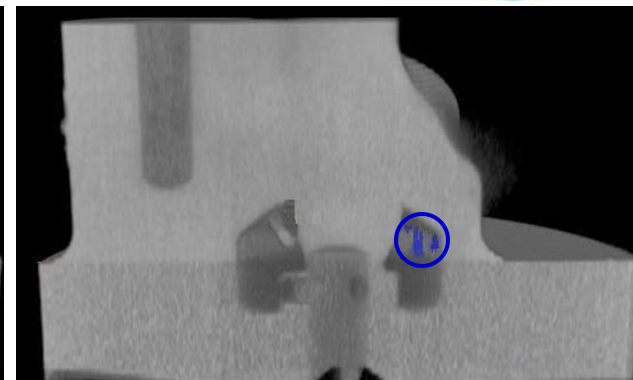

Rear

#	Work Order	ASI #	Slice Height	# of Incidents	Observation of Powder
1	2017-V-0393	#1 - As Received	127 - 132	1	Chamber Side Wall, opposite Inlet 1 (40°)
2	2017-V-0413	#1 - Doped	136	1	Chamber Internal Side Wall, below Inlet 2 (90°)
3			127 - 132	1	Chamber Side Wall, opposite Inlet 1 (40°)
4			125	3	Chamber Internal Side Wall (45°, 135° & 260°)
5			118	2	Chamber Bottom (45° & 135°)
6			2017-V-0441	#1 - Cleaned	
7	2017-V-0398	#2 - As Received	118	2	Chamber, Interior & Exterior Wall (90° & 125°)
8	2017-V-0448	#2 - Cleaned	118	1	Chamber, Interior Wall (90°)
9	2017-V-0402	#3 - As Received	130 - 131	1	Chamber Side Wall, opposite Inlet 1 (10°)
10	2017-V-0453	#3 - Cleaned			
11	2017-V-0403	#4 - As Received / Doped	117 - 119	2	Chamber Bottom (100° & 180°)
12		#4 - Cleaned			

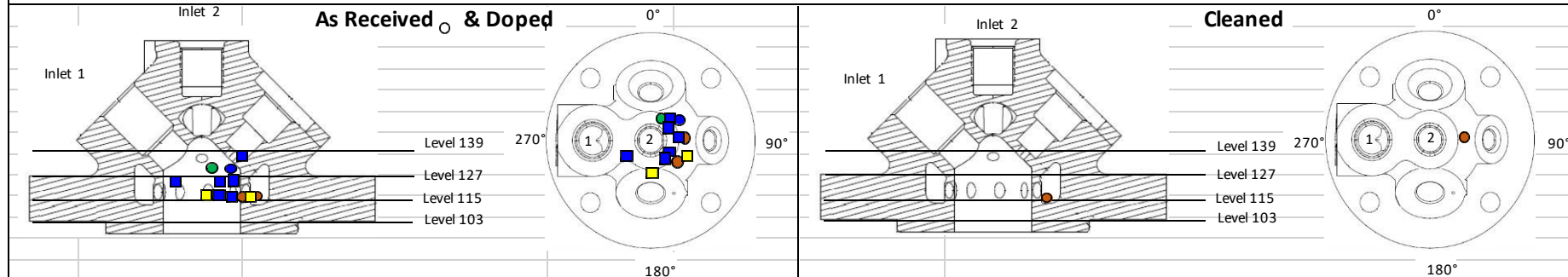

Component # 1 Analysis – As Received VS. Cleaned

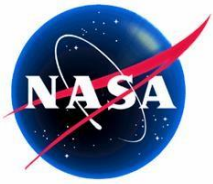

A total of four components were manufactured and cleaned using the prototype method. This method effectively removed process and doped powder from 11 of the 12 excursions. Following CT analysis of the first component, where only one small patch of remnant powder was found, it was decided to dope half of the components for test capability.

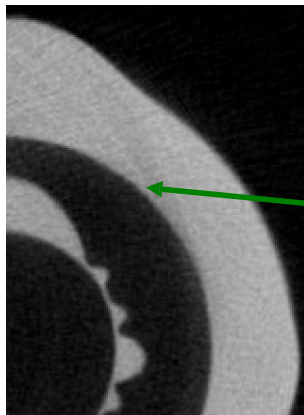
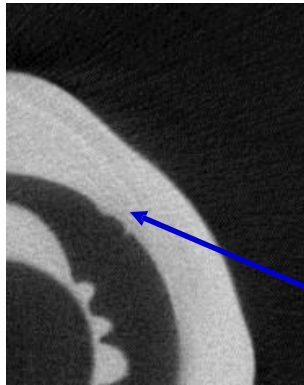

Cleaned Component,
Powder Removed

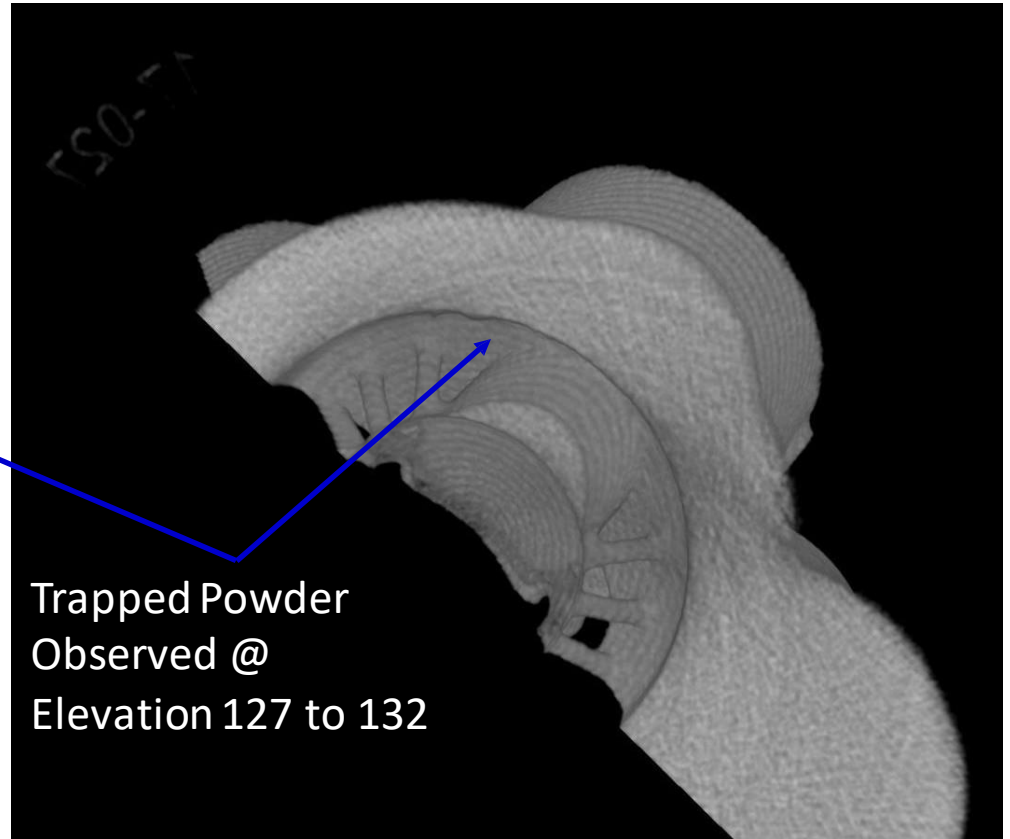

Component # 1 Analysis – Doped VS. Cleaned

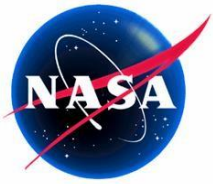

Inconel 718 powder was used to dope component #1 by adding powder into the top inlet holes. The part was then shaken for several minutes, then flipped for additional shaking as a means to work the powder into the component.

Powder deposition occurred in different areas as compared to the accrual locations of “As Received” test articles. As a result, the doping process does not appear to represent actual AM powder entrapment mechanisms. It may, however, represent powder dispersal during handling prior to post production processing.

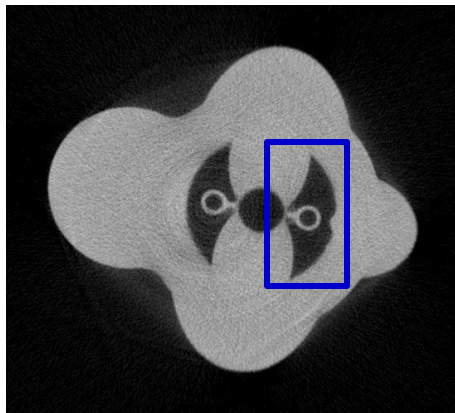

Trapped Powder
Observed @
Elevation 136

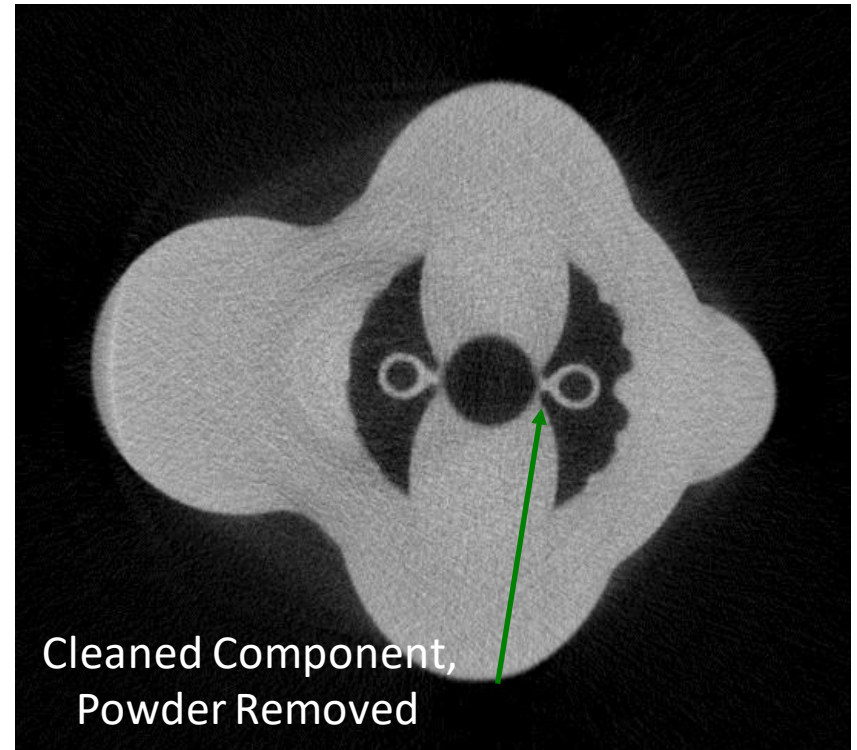
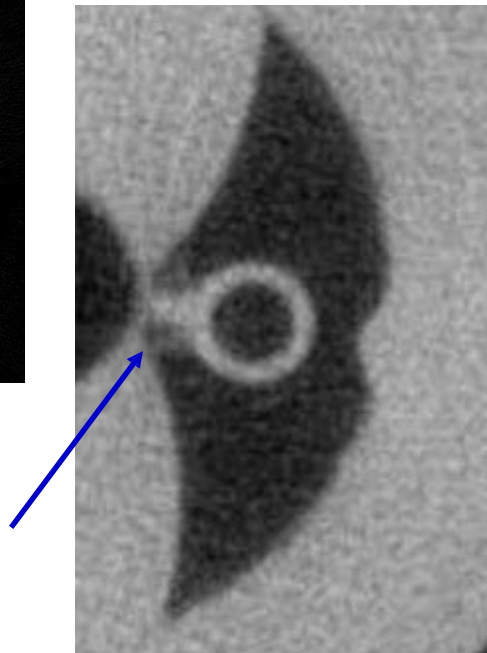

Cleaned Component,
Powder Removed

Component # 1 Analysis – Doped VS. Cleaned

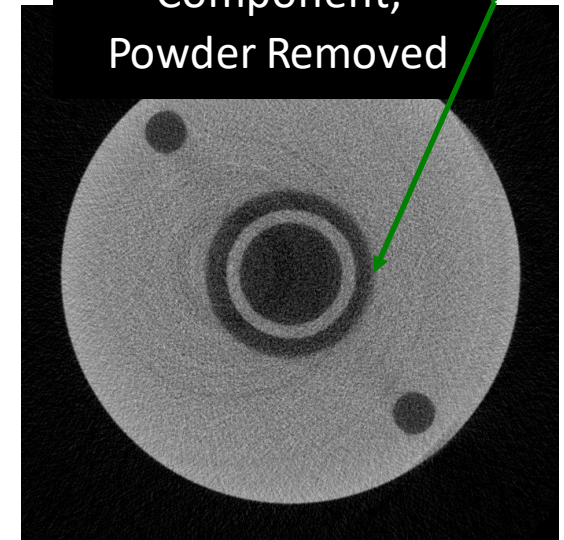
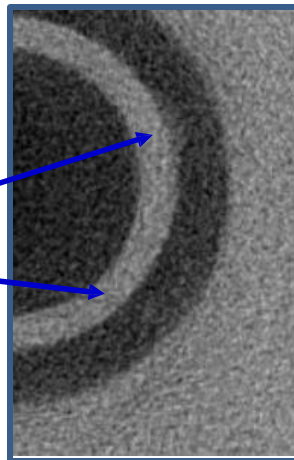
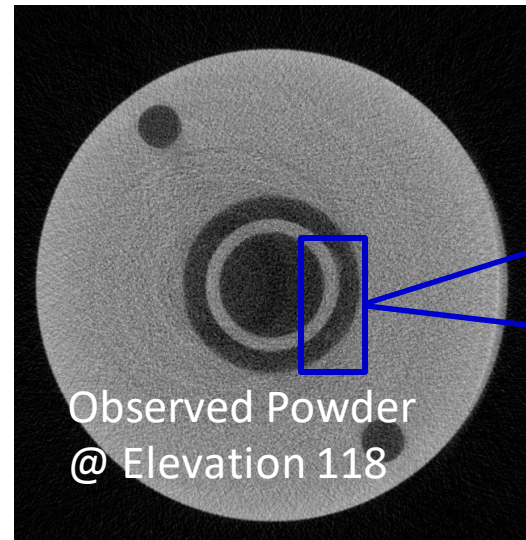
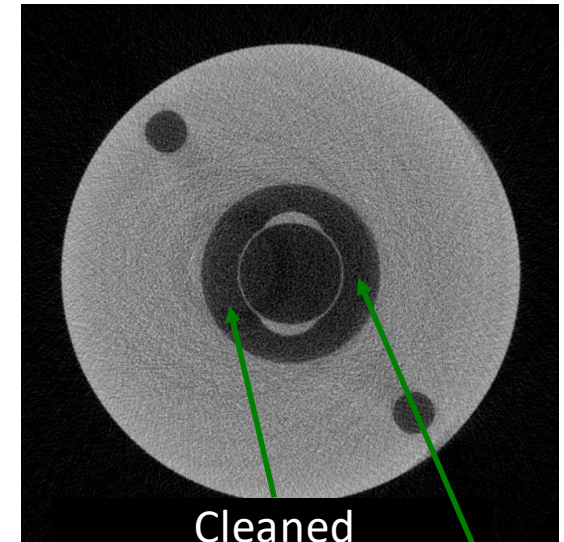
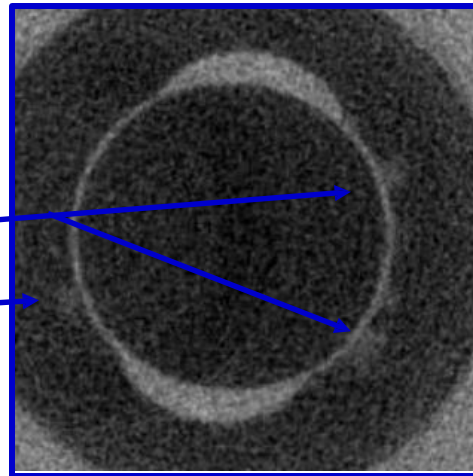
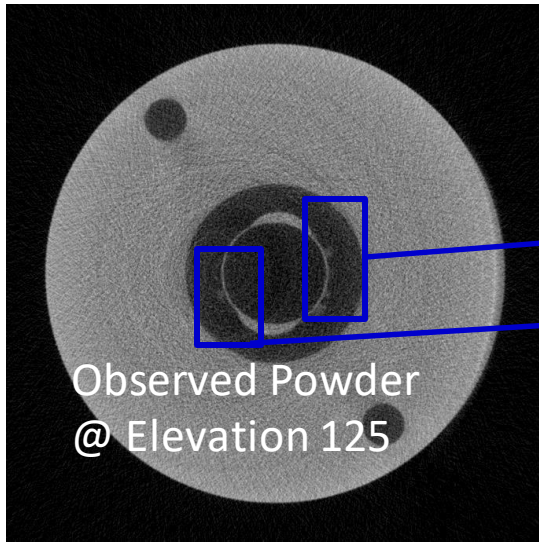
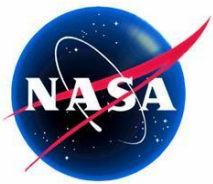

Component # 2 Analysis – As Received VS. Cleaned

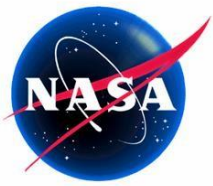

Powder was observed in two locations. Cleaning removed powder at one location but not at the interior wall / bottom chamber surface. A wire EDM cut of the affected zone did not show the presence of any mechanical defect, thereby indicating that the artifact in question was most likely powder.

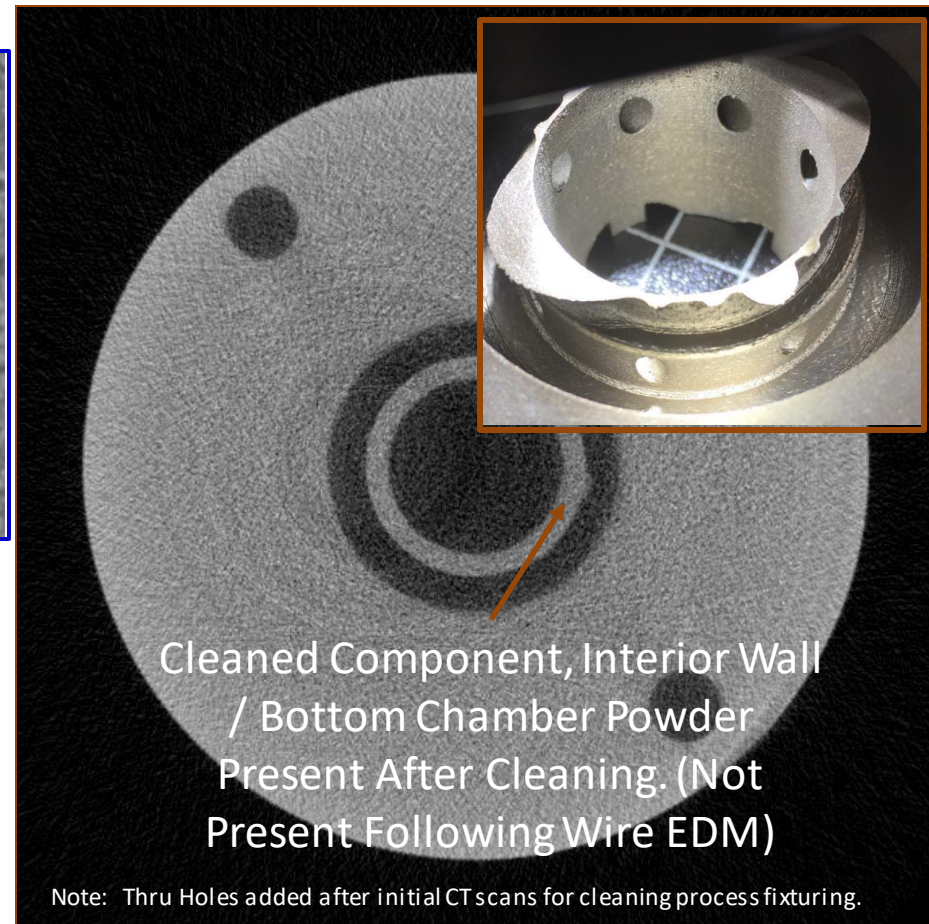
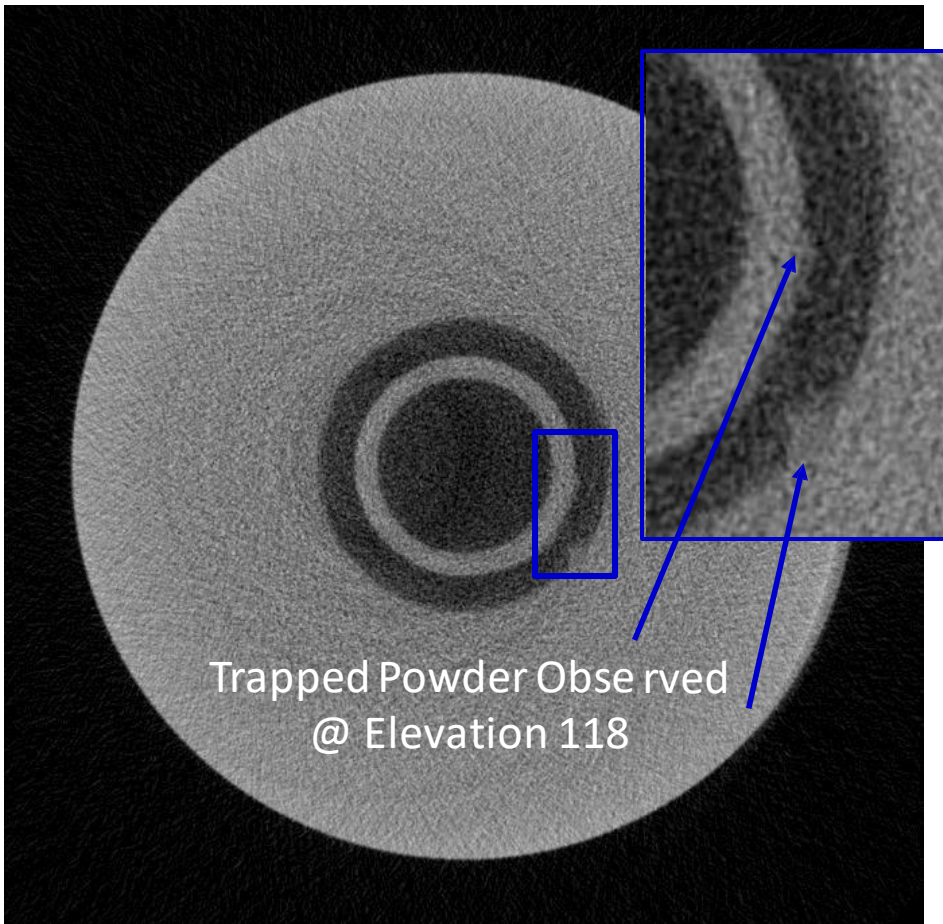

Component # 3 Analysis – As Received VS. Cleaned

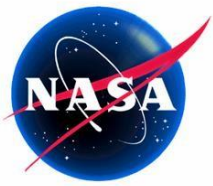

Powder observed at the main cavity side wall on the upper corner.
Following cleaning, the powder is absent.

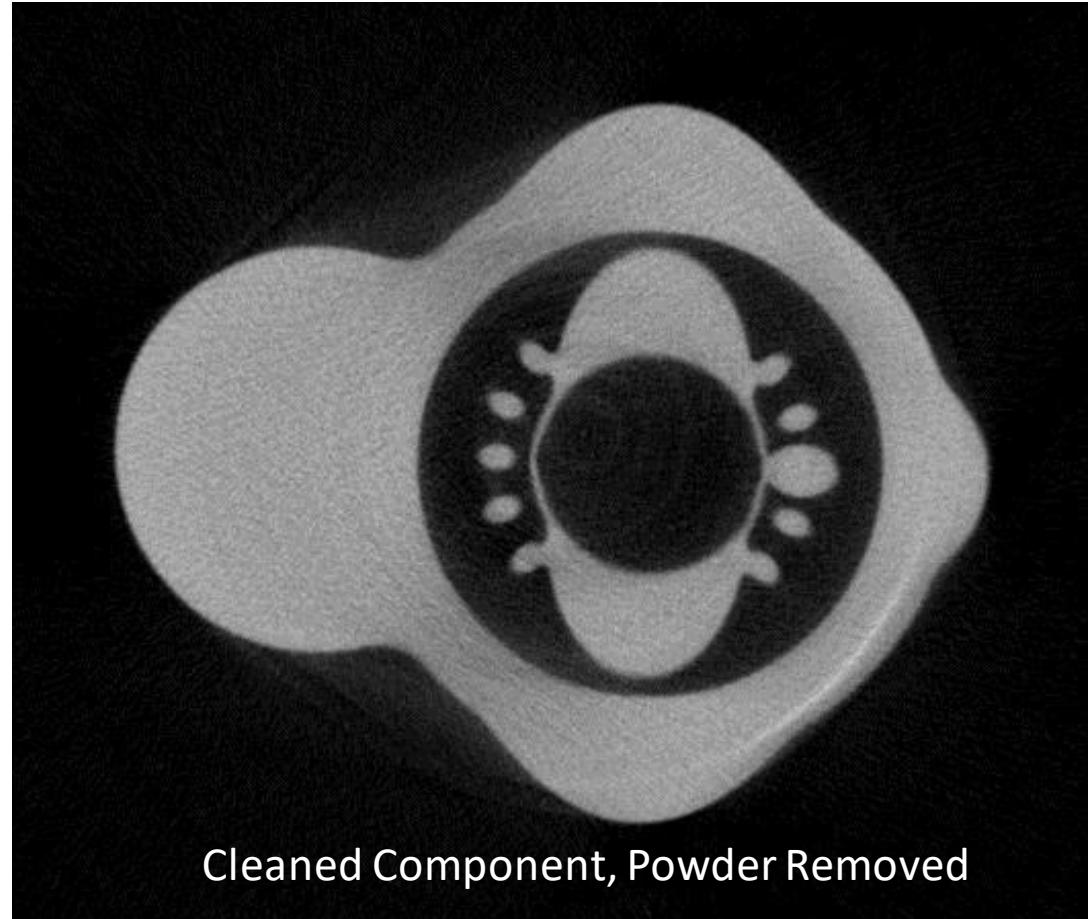
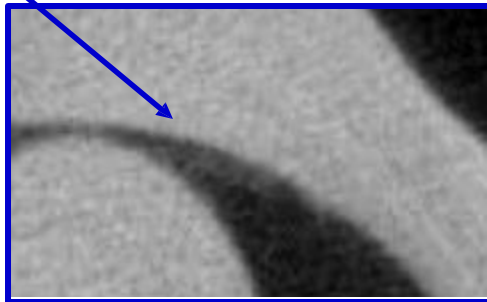
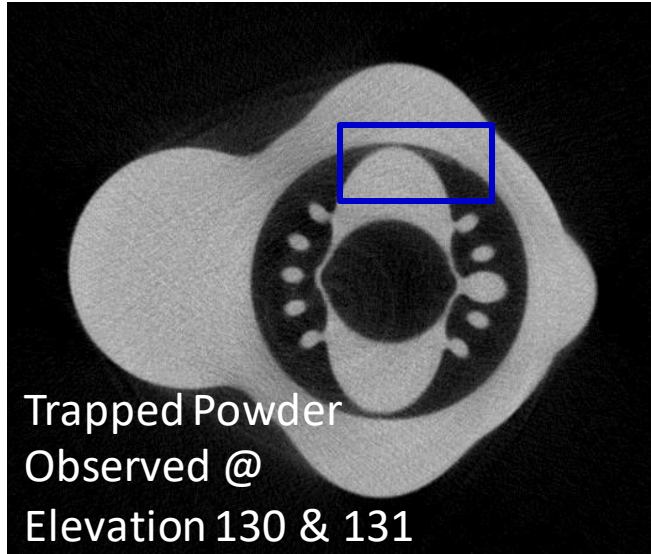

Component # 4 Analysis – As Received / Doped VS. Cleaned



Powder observed at the bottom main cavity in two locations, cavity angled outlet and at the exterior wall. Remnant powder is absent following cleaning.

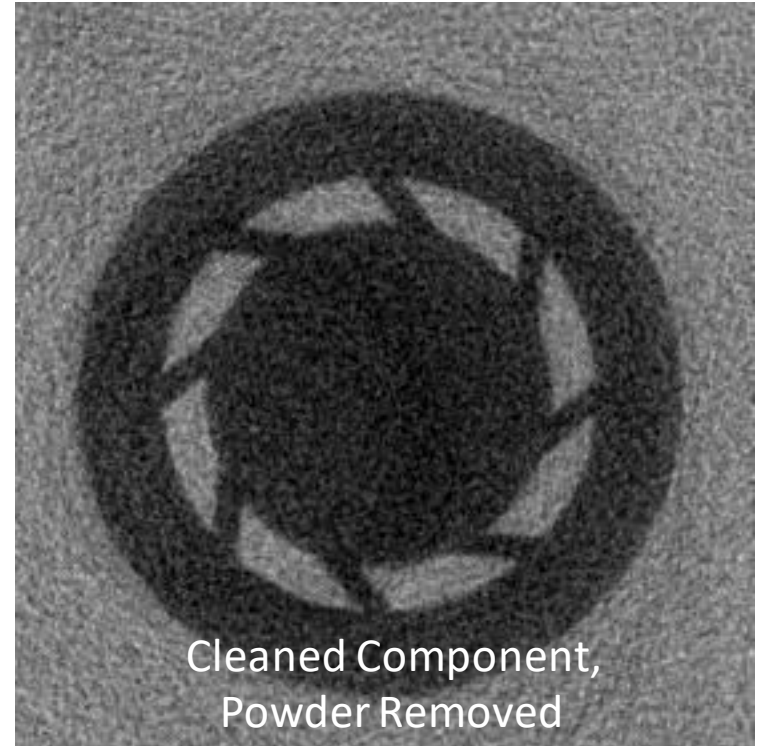
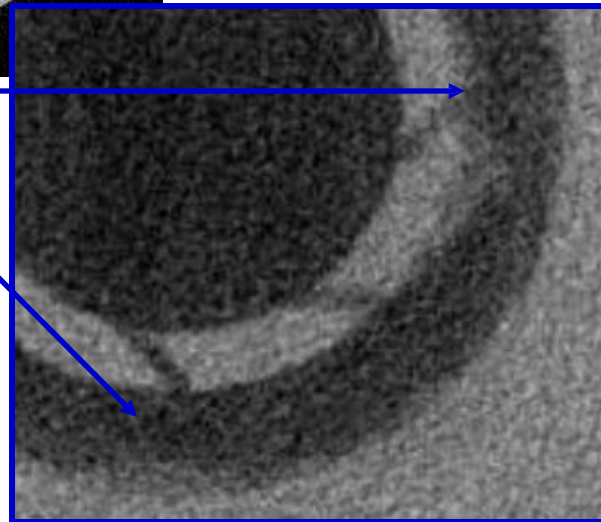
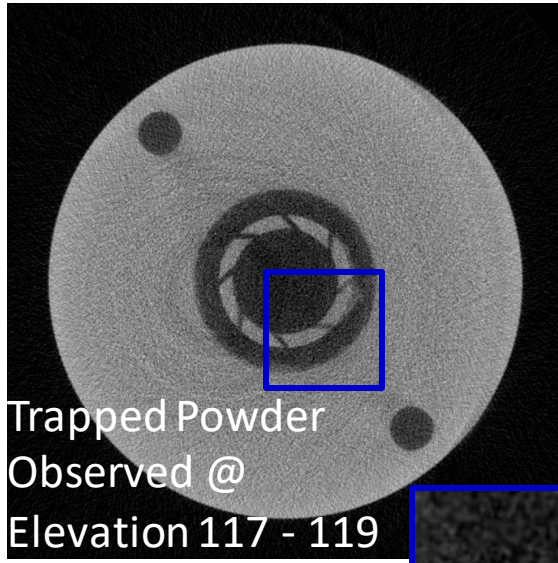

Acknowledgements



Material Test, Chemistry & Contamination Control Branch: Dr. Eric Fox, Mark Mitchell, Richard Boothe (Design Ideas and Test)

Additive Manufacturing/ Structural Materials: Dr. Omar Mireles, Ken Cooper, Brian West (Test Fixture & Component Fabrication)

Mechanical Materials & Structures: Dr. Ronald Beshears & David Myers (CT Scans)

Experimental / Mechanical Fabrication: Myron Tapscott, Jeff Clouch, Jim Hargrove (Test Fixture Fabrication)

Materials Test Engineering: Preston Jacobs (CAD Design)

Questions?

Kevin S. Edwards

Contamination Control Engineer

Jacobs ESSSA Group

Materials and Processes Laboratory,

Chemistry and Contamination Control

Marshall Space Flight Center, AL 35812

Phone: (256) 961-2676

E-mail: kevin.s.edwards@nasa.gov